

TOMMA

FOLDING SLIDING STACKING SOLUTIONS

SOFT CLOSE

FAST FIX DOOR SYSTEM



FAST FIX SOFT CLOSING DOOR SYSTEM

The Tomma Softclose fast fix sliding door system, is a ground breaking soft close system with world class features and performance for all sliding doors up to 80kg. Designed in Australia by a specialist team of engineers with over 100 years experience. Not only does it stop banging of sliding doors, it removes any chance of young children getting their fingers caught. This fast fix door system uses a fast fix spring loaded bracket allowing for a fast & easy way to mount your door. It can be installed by tradesmen and handymen alike. This system uses the most advanced European softcloser technology. The Tomma Softclose is a unique system designed to bring world class benefits to the Australian household. Support Aussie innovation and engereering and ask for the Tomma Softclose on your doors.

Features & Benefits:



- Easy to install
- Tested to over 100,000 cycles
- Australian Designed and Engineered
- Fast Fix Bracket Providing A Fast & Easy Door Mounting Process
- Childsafe Operation
- Advanced European Softcloser Technology
- Each Soft Close Cylinder is Robotically Tested

TOMMA

FOLDING

SLIDING

STACKING

SOLUTIONS

A MAMMOTH INDUSTRIES COMPANY







Mammoth Industries is a privately owned company with our origins in Melbourne Australia. Our company is a leading producer of Rolling, Folding and Stacking systems throughout a number of different industries across the globe. The key to our success is our ability to listen to our client's needs and take an innovative approach to product development, through to engineering and then on to manufacturing. This approach gives our client's a finished product that is easy to use, well-functioning and of a superior quality.

Craig Lang, Managing Director and Founder of Mammoth Industries says, "Having worked in the industry for many years I could see the way that manufacturing was rapidly changing and realised early on the only way to keep in front, and offer our client's the best solutions would be to partner with some of the leading manufacturing facilities around the world. Each of these companies have their own unique capabilities allowing us to access all the latest machinery and manufacturing methods available today. This manufacturing principle combined with our leading engineering and design team enables us to offer our clients the best solutions for their applications and not just the best solution based upon what products are available. I'm proud of the fact we have built an enviable reputation for quality and reliability and now have established long term clients throughout Australia, North America, Europe and Asia. We believe by working with our company and utilising our 100 plus years of design and industry experience we are able to offer your company a competitive edge in your chosen working environment. We listen, understand your needs, offer solutions and become a partner in helping your business to grow."

Mammoth Industries will "make your ideas move".

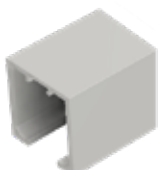

TOMMA Soft Close Fast Fix Door System Includes :

	DESCRIPTION	QUANTITY
	Stop Catch	1
	End Trolley	1
	Fast Fix Door Soft Close	1
	Trigger Plate	1
	Fast Fix Bracket	2
	Pressed Spanner	1
	Track insert	1

Soft Close Door Weight Guide :

0-20kg - 20-TSC15-FF-SCFFFS 20-40kg - 20-TSC30-FF-SCFFFS 40-60kg - 20-TSC50-FF-SCFFFS 60-80kg - 20-TSC70-FF-SCFFFS

Available Accessories :



Plastic Bottom Door Guide

20-200-GU



Single Wheel bottom guide

20-BG110-SS



Single Track Mounting Bracket

20-TB100-CA

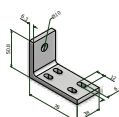

Double Track Mounting Bracket

20-TB200-CA

Available Tracks :

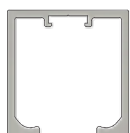

6.0 Meter aluminium top track
Clear Anodised 2.0, 3.0, 4.0 lengths available

10-60-SCTT2000-CA

10-60-SCTT3000-CA

10-60-SCTT4000-CA

10-60-SCTT6000-CA



6.0 Meter aluminium bottom track
Clear Anodised 2.0, 3.0, 4.0 lengths available

10-60-BT2000-CA

10-60-BT3000-CA

10-60-BT4000-CA

10-60-BT6000-CA

FITTING INSTRUCTIONS

STEP 1. PRE-LOADING SOFTCLOSE UNIT

1. Push forward until catch clicks down into loaded position.

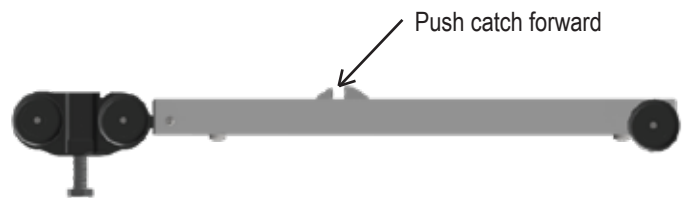

STEP 2. INSERTING STOP CATCH

1. Hold end catch with screw heads facing down and catch finger facing the outward direction and insert into track at track opening.
2. Slide in track to position required and tighten clamp screws to hold firmly in place. The stop catch can be adjusted after door fitment if required.

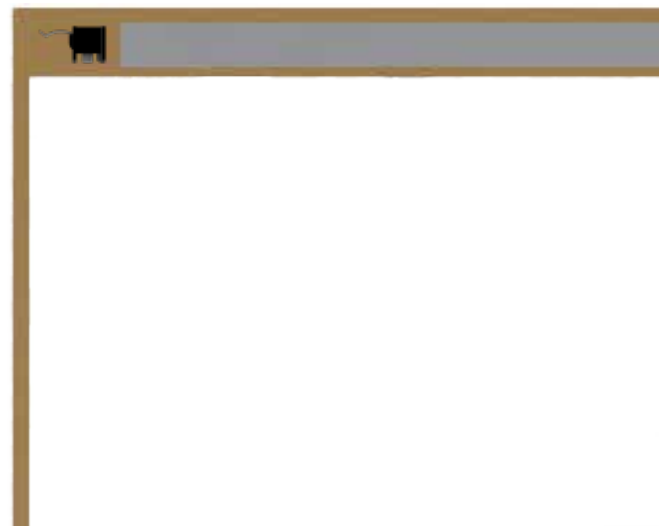

STEP 3. INSERTING REAR TROLLEY

1. Insert rear trolley into track with the doorstop groove entering track first.
2. Slide trolley along track to required location.

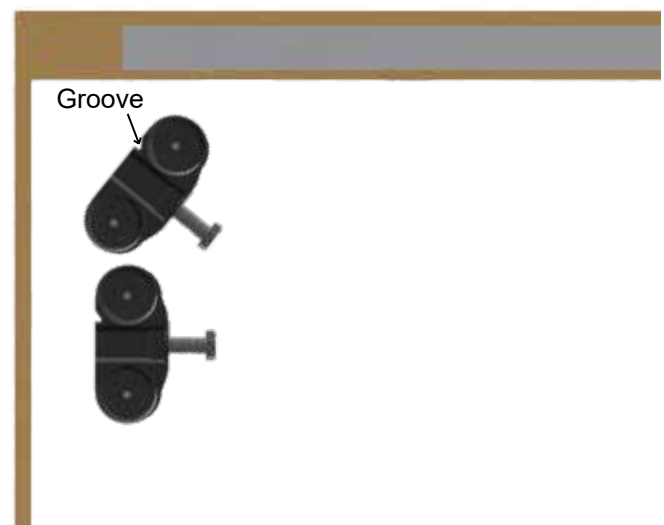

FITTING INSTRUCTIONS

STEP 4. INSERTING SOFTCLOSE

1. Hold carriage vertical and insert back wheels at track opening
Position A.
2. Slide back wheels along track and lift bracket end towards
track Position B.
3. Slide carriage along track until the bracket end is aligned and
can be inserted into track via opening position C.

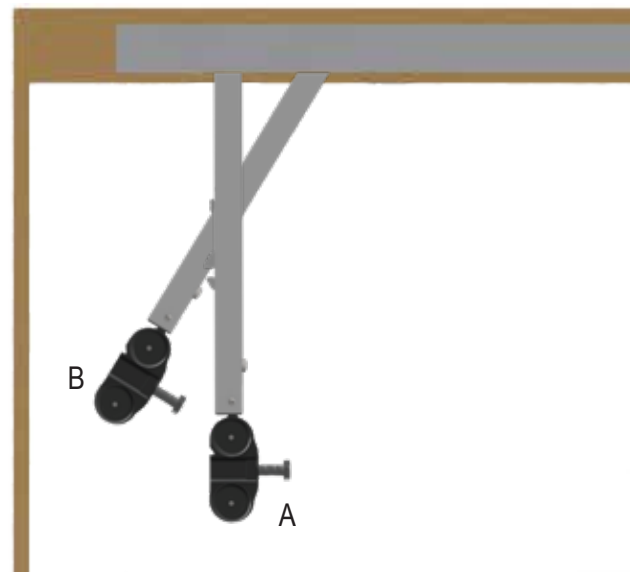

STEP 5. INSERTING TRIGGER PLATE

1. WIPE TOP TRACK TO ENSURE NO DEBRIS IS LEFT TO
INTERFERE WITH WHEELS.
2. Ensure that all screws fixing the track to the door frame are
countersunk below the surface.
3. Insert trigger as shown with flat side sliding into track groove.
Ensure it is facing the **correct direction** as shown in diagram.
4. Fix track insert in place using the screws provided.
5. Ensure that the insert is fitted flush with door track.



TRACK PLATE MUST FIT FLUSH TO INSIDE OF TOP TRACK.

ENSURE THAT ALL TRACK FIXING SCREWS ARE

COUNTERSUNK BELOW THE SURFACE.

FITTING INSTRUCTIONS

STEP 6. FITTING OF TROLLEYS TO FAST FIX BRACKET

1. Fix the the fast fix door bracket onto the top of the door, at each end of the door with the screws provided. Ensure the brackets are fitted 70mm from the edge of the door.
2. Carefully lift the rear of the door, lining up the rear fast fix bracket with the rear trolley. Slide and hold fast fix bracket open, whilst locating the rear trolley bolt into the bracket opening. Once the bolt is inside the opening, release fast fix bracket to lock into place.
3. Slide the rear of the door into cavity frame. Proceed to locate the front fast fix bracket inline with the front trolley bolt. Once the bolt is inside the bracket opening, release latch to lock in place.
4. NOTE: Do not forcefully slam softcloser this is to be used as a closing aid.

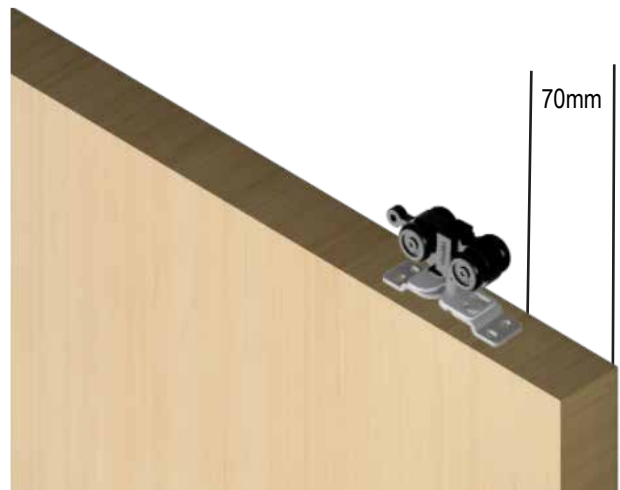

Rear Door View

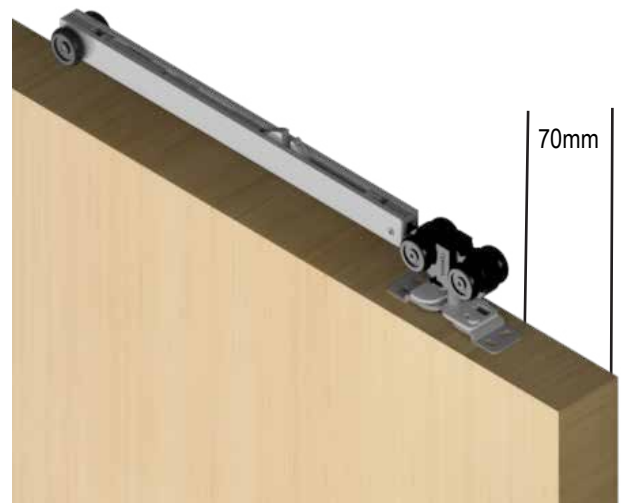

Front Door View

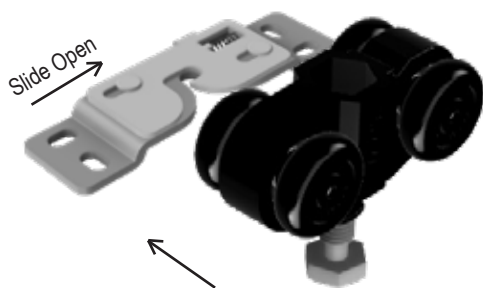

Push bolt into bracket opening

FITTING INSTRUCTIONS

STEP 7. DOOR ADJUSTMENT

1. Use the spanner provided to adjust the door height up to requirement.
Ensure both ends are adjusted equally to ensure a level operating door.
2. Ensure trigger plate is catching the door in the correct position.
Simply loosen screws on trigger plate and slide along track until desired position is located.



Technical Specifications :

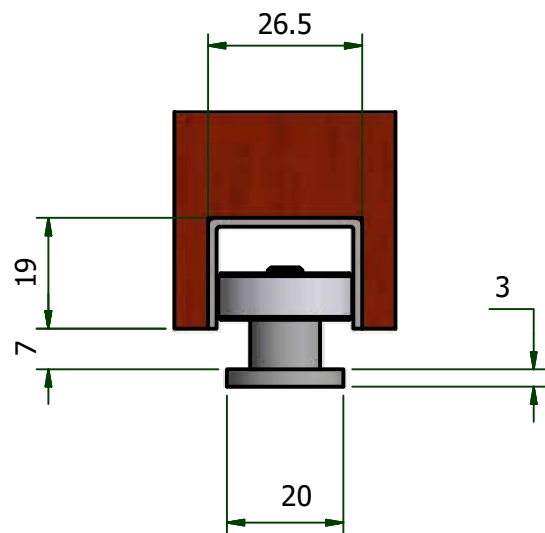
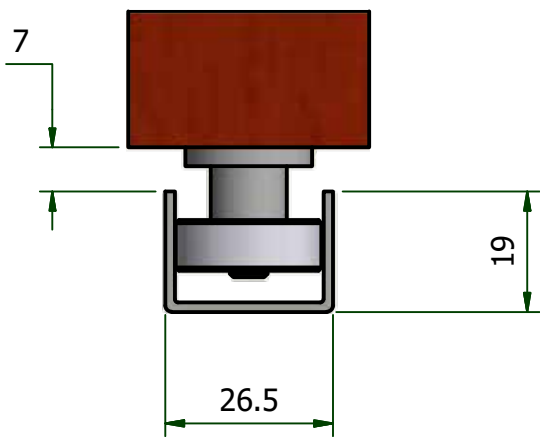
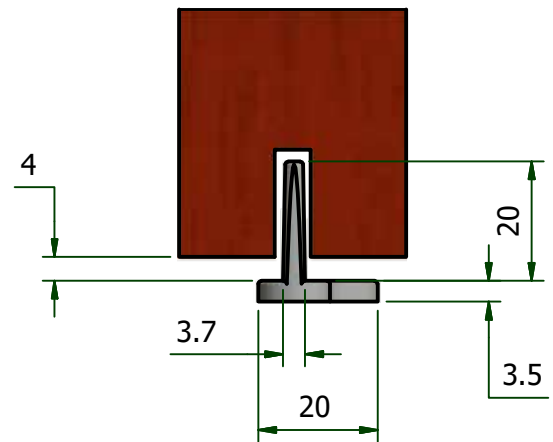
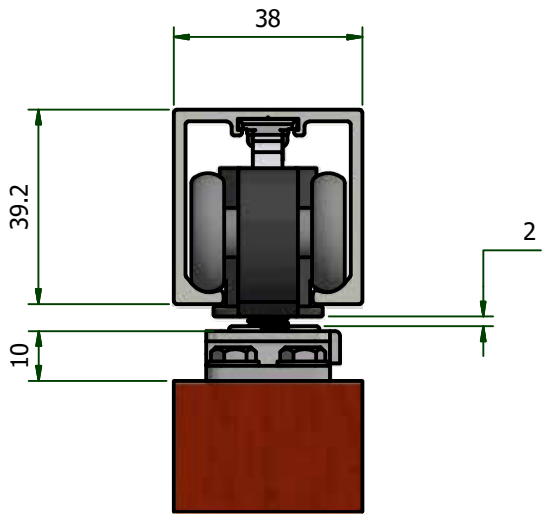

TOMMA SOFTCLOSE

SOFT CLOSING SLIDING DOOR SYSTEM
 A ground breaking soft close system with world class features and performance for all sliding doors up to 70kg. Designed in Australia by a specialist team of engineers with over 100 years experience. Not only does it stop banging of sliding doors it remove any chance of young children getting there fingers caught in a sliding door. Can be installed by tradesman and handyman alike.



TOMMASLIDE



The superior design and build quality of the TOMMASLIDE sliding door system will quite literally open the doors of opportunity to your dreams, designs and projects. The TOMMASLIDE system is a wonderful mixture of style and function with the incredible build quality giving not only peace of mind, but great looks too. Backed by our exclusive 10 year warranty.



Distributed by

45 Commercial Drive, Thomastown, Victoria. 3074
 Phone +61 3 9466 1088 Fax + 61 3 9466 3088
 info@tomma.com.au www.tomma.com

A Mammoth Industries Company



