

ACTUAL SIZE

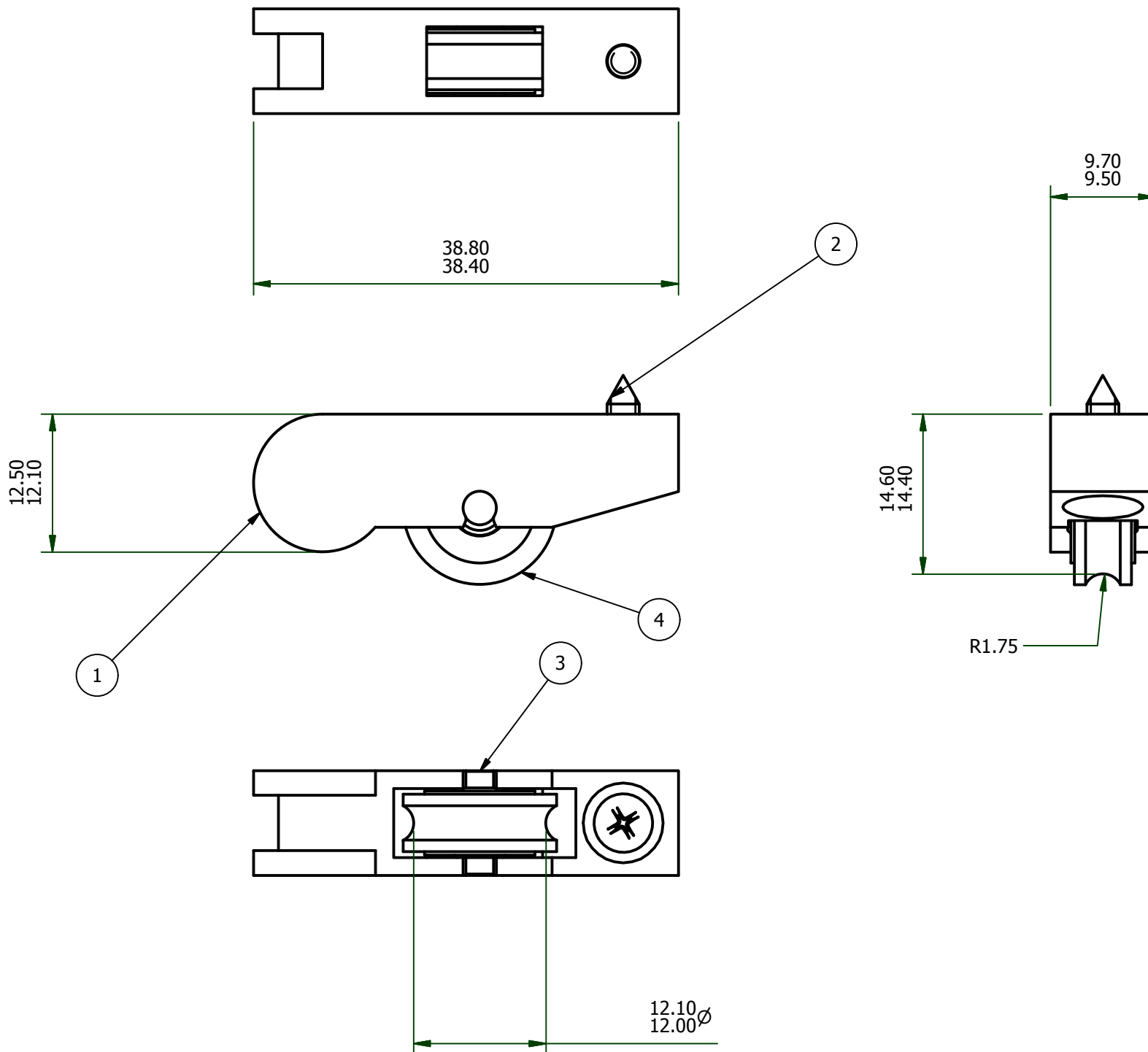

Parts List

ITEM	QTY	PART NUMBER	DESCRIPTION
1	1	M-85-0423- Carriage	Nylon Natural
2	1	ISO 7049 - ST2.9 x 6.5 - C - H	(Sheetmetal) Tapping Screw
3	1	M-141 Pin	Brass
4	1	M-141 Wheel	Acetal Black

Designed by Anthony	Weight N/A	Material	Date 25/06/2009	Part No. 45-141-N
		Title SHOWCASE ROLLER		
		This drawing and the information contained are the property of Mammoth Industries Pty Ltd. They may not be reproduced or used in whole or part without the prior written permission of Mammoth Industries Pty Ltd.		Revision
File Ref: 45-141-N.iam				