

LOAD RATING: 45kg Max.

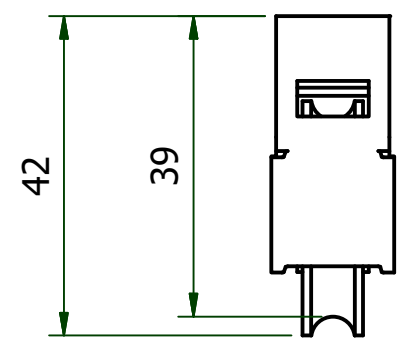
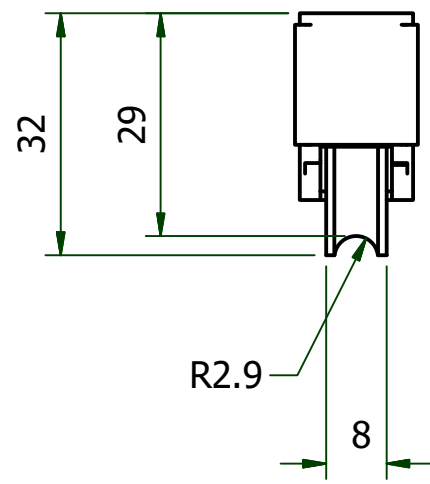
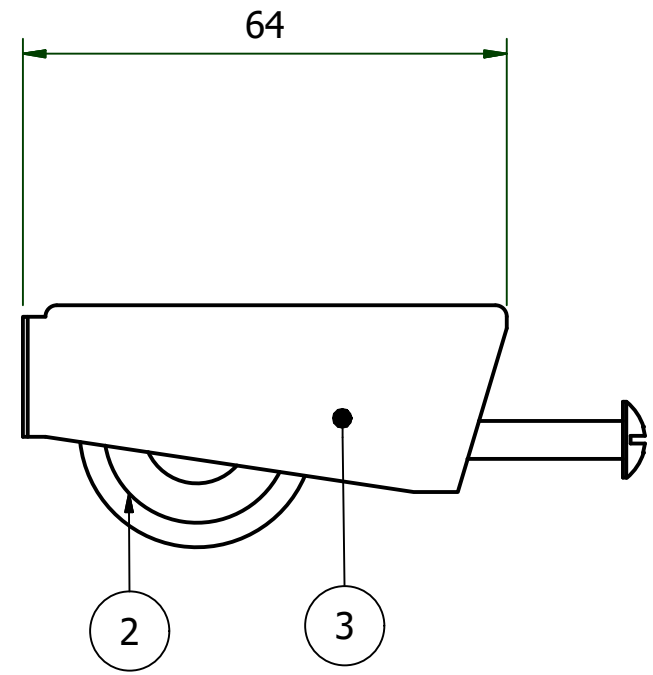
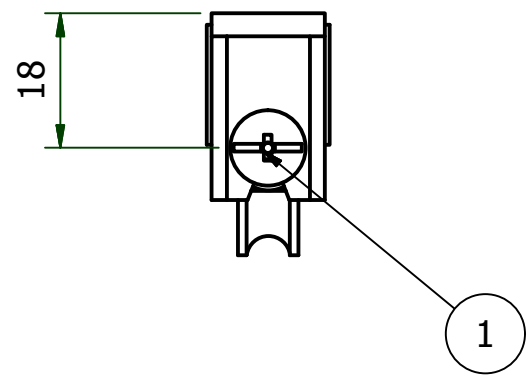
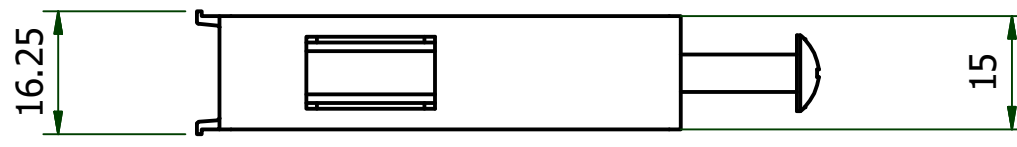

PARTS LIST

ITEM	QTY	DESCRIPTION	MATERIALS
1	1	Adjusting Screw and Nut	Stainless Steel
2	1	Wheel	Nylon Tyred Sealed Bearing
3	1	Outer Carriage	Glass Reinforced Nylon

DESIGNED BY Robert James	CHECKED BY	MATERIAL	DATE 16/09/2016	PART NO. <b>45-328-NA</b>	WEIGHT N/A
		TITLE <b>45-328-NA SLIDING DOOR ROLLERS</b>			ALL DIMENSIONS ARE IN MILLIMETERS (UNLESS OTHERWISE STATED)
		THIS DRAWING AND THE INFORMATION CONTAINED ARE THE PROPERTY OF MAMMOTH INDUSTRIES PTY LTD. THEY MAY NOT BE REPRODUCED OR USED IN WHOLE OR PART WITHOUT THE PRIOR WRITTEN PERMISSION OF MAMMOTH INDUSTRIES PTY LTD. <small>File Ref: 45-324-SNA.iam</small>		REVISION	SIZE <b>A3</b>